

## SPECIFICATIONS

	Input Voltage Range	Output Voltage	Output Current (Cont.)	Output Current (Peak)	Line Regulation	Load Regulation	Output Ripple (Max)	Efficiency (Typical)	Fuse
ICT612-5A	6.0 – 10.0 VDC	13.8 VDC +/- 150 mV	5.0 Amps	5.0 Amps	0.70%	0.30%	35 mV RMS	88%	20 Amp
ICT612-15A	6.0 – 10.0 VDC	13.8 VDC +/- 150 mV	12.0 Amps	15.0 Amps	0.70%	0.30%	35 mV RMS	88%	50 Amp
ICT1224-15A	10.5 – 18.0 VDC	27.6 VDC +/- 150 mV	12.0 Amps	15.0 Amps	0.45%	0.30%	35 mV RMS	92%	50 Amp



## ICT INDUSTRIAL SERIES STEP UP (BOOST) CONVERTERS

INSTRUCTION MANUAL



INNOVATIVE CIRCUIT TECHNOLOGY LTD.

855-183-000

## ICT INDUSTRIAL SERIES (STEP-UP CONVERTERS)

The ICT Industrial Series converters are non-isolated DC to DC converters designed for use on negative ground systems. These models are step-up converters that provide an output voltage higher than the input voltage. Each converter is designed for high efficiency and long service life. The rugged case and modular design have proven durable in harsh environments. Extra silicone is used for vibration and moisture resistance. Standard features include: fuse protection, high surge capacity, easy access mounting holes, and a terminal block connector.

These instructions should be read before using the product and it should be saved for future reference.

### SETUP

- ▶ Mount converter securely.
- ▶ Do not apply power until unit is completely wired.
- ▶ For best results, wire converter directly to battery using heavy gauge wire.
- ▶ Do not connect the output directly to a power source.
- ▶ Wire the output through an external fuse. Do to the nature of the step-up converter design, the output is connected to the input when the unit is disabled.

### WARNING

- ▶ Do not place unit on or near sources of heat/moisture.
- ▶ Incorrect wiring may result in serious damage to both the converter and equipment wired to the converter.
- ▶ Unit service should be done at ICT factory.

### TROUBLESHOOTING

- ▶ Check fuse inside unit, if blown, replace with correct fuse.
- ▶ Check for proper voltage at input while converter is under load.
- ▶ Check for erratic voltage conditions at input, which might cause overvoltage circuit to trigger.

### CONNECTIONS

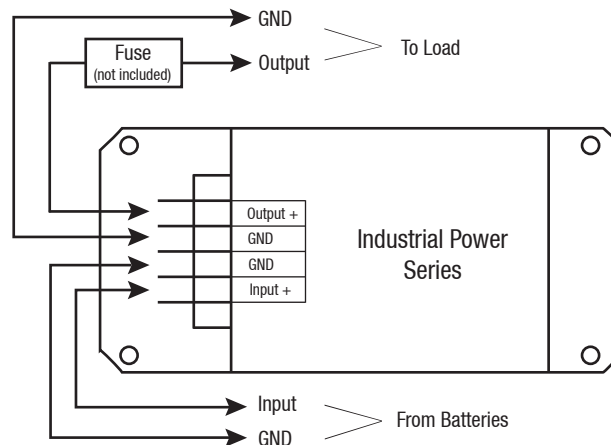

### LIMITED WARRANTY

ICT Ltd. warrants to the original consumer purchaser that this product shall be in good working order, free from defects in materials and workmanship, for a period of one (1) year from the date of purchase. Should failure occur during the above stated time period, then ICT will, at its option, repair or replace this product at no additional charge except as set forth below. All parts, whether for repair or replacement, will be furnished on an exchange basis. All exchange pieces become the property of ICT. This limited warranty shall not apply if the ICT product has been damaged by unreasonable use, accident, negligence, disaster, service, or modification by anyone other than the ICT factory.

Limited warranty service is obtained by delivering the product during the above stated one (1) year warranty period to an authorized ICT dealer or ICT factory and providing proof of purchase date. If this product is delivered by mail, you will insure the product or assume risk of loss or damage in transit, and prepay shipping charges to the factory.

Every reasonable effort has been made to ensure that ICT product manuals and promotional materials accurately describe ICT product specifications and capabilities at the time of publication. However, because of ongoing improvements and updating of ICT products, ICT cannot guarantee the accuracy of printed materials after the date of publication and disclaims liability for changes, errors or omissions.

If this ICT product is not in good working order, as outlined in the above warranty, your sole remedy shall be repair or replacement as provided above. In no event will ICT be liable for any damages resulting from the use of or the inability to use the ICT product, even if an ICT employee or an authorized ICT dealer has been advised of the possibility of such damages, or for any claim by any other party.

ICT reserves the right to make changes without further notice to any products or documentation for improvement of reliability, function, or design.

ICT Ltd. does not recommend use of its products in life support applications wherein a failure or malfunction of the product may directly or indirectly threaten life or cause injury. The user of ICT products, which are to be used in life support applications as described above, assumes all risks of such use and indemnifies ICT against all damages.