

ICT POWER COMMANDER SERIES

The ICT Power Commander is an under voltage protection device intended for mobile applications. This device protects the vehicle battery from over-discharge by shutting off the load, using a user defined time delay, once the vehicle ignition is turned off, or when the battery is discharged below a selectable cut-off voltage. The time that the connected load will be allowed to run after the ignition is turned off is selectable between 5 seconds and infinity using a DIP switch. An internal buzzer provides an audible warning of events (can be disabled), while a warning output is available for notification to external devices that power will be shut down. This product incorporates an aluminum chassis and heavy duty connector which have been designed for use in rugged environments.

Figure 1: The ICT Power Commander, External View

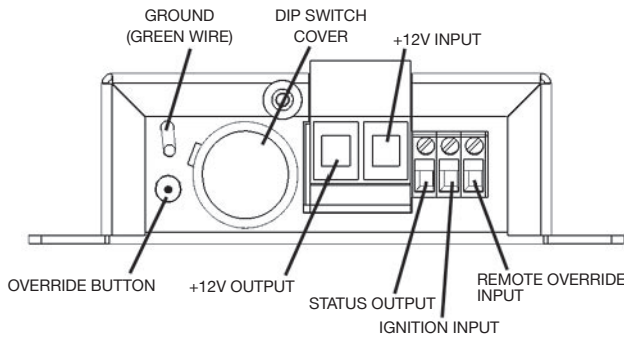

PRODUCT SPECIFICATIONS

Nominal Input Voltage	13.80 Vdc
Maximum Load Current	30 A
Standby Current	8 mA
Operating Current	95 mA
Adjustable Time Delay	5 seconds to 10 hours or infinity
Override Time Delay	15 minutes
High Voltage Disconnect	18.0 Vdc
Adjustable Low Voltage Disconnect	10.5 – 12.5 Vdc
Low Voltage Disconnect Delay	5 minutes
Turn-On Threshold (DC Voltage Detection)	> 13.5 Vdc
Timer Start Threshold (DC Voltage Detection)	< 13.0 Vdc
Ignition Input On Threshold	> 5.0 Vdc
Ignition Input Off Threshold	< 3.0 Vdc
Status Output: Maximum Current	30 mA
Size	4.8" x 2.5" x 1.5"
Weight	0.4 lbs

FEATURES

Adjustable Time Delay: the shutdown time delay can be set between 5 seconds and 10 hours or infinity using the DIP switches. On "infinity" setting, the unit will remain on indefinitely until a over/under voltage condition exists, or the override button is pressed.

Optional Ignition Switch Activation: the Power Commander can be connected to the vehicle ignition switch. If a voltage greater than 5 volts is present at the IGNITION input, the load will be turned on. The shutdown timer starts running as soon as the ignition is turned off.

DC Voltage Detection: if Ignition Switch Activation is not used, the Power Commander will react to changes in the battery voltage. The load will be turned on when the engine is turned on and the battery voltage is above 13.5 volts. The shutdown timer will start running as when the engine is turned off and the battery voltage drops below 13.0 volts.

Low Voltage Disconnect: shuts down the load if the battery voltage drops below a user selectable cut-off voltage (set using DIP switches) for over 5 minutes. The load can be turned back on by starting the vehicle engine or by pressing the override button.

Critical Low Voltage Disconnect: shuts down the load if the battery voltage drops 0.5 volts below the user selectable cut-off voltage for over 10 seconds. The 10 second delay is to prevent disconnection while starting the vehicle.

High Voltage Disconnect: shuts down the load at 18 volts to protect the equipment connected to the Power Commander. The internal buzzer alarm will also sound if it is enabled.

Reverse Polarity Protection: the unit will not operate when the polarity is reversed. No damage to the unit will result.

Delayed Turn-On: To protect sensitive equipment from voltage spikes that can occur during the engine startup process, there is a 2 second delay when the engine is started before the Power Commander will turn on the load.

Override Button: pressing the override button will allow 15 minutes of emergency operation after the Power Commander shuts down the equipment connected. Holding down the override button for 2 seconds while the timer is running will stop the timer and shut down te equipment connected to the Power Commander.

Remote Override Button Input: can be used in installations where the Power Commander override button is not in a convenient location.

Status Output: provides a warning signal 2 minutes before the timer shuts down.

Buzzer Alarm: warns when less than 2 minutes is remaining before the timer shuts down (can be disabled).



ICT POWER COMMANDER 12 VOLT

INSTRUCTION MANUAL



WARNING

- ▶ Avoid mounting the unit near sources of heat or moisture.
- ▶ The green ground wire must be attached to vehicle ground for proper unit operation.

SETUP

Wiring: Connect the vehicle 12V battery to the BATT terminal on the Power Commander using #10 Gauge wire and an appropriate fuse (maximum 30 Amps). Connect your load to the LOAD terminal on the Power Commander.

Grounding: Attach the green ground wire to vehicle chassis.

Time Delay: The shutdown time delay is set with DIP switches. To set the time delay, remove the round DIP switch cover (see Figure 1) and set switches 1 to 4 of the DIP switch to the desired time delay in Table 1.

Note: The factory default time delay is 1 hour.

Low Voltage Disconnect: The Low Voltage Disconnect is set with DIP switches. To set the cut-off voltage, remove the round DIP switch cover (see Figure 1) and set switches 6 and 7 of the DIP switch to the desired cut-off voltage in Table 1.

Note: The factory default Low Voltage Disconnect is 11.0V. This does not need to be changed for most installations.

Figure 2: ICT Power Commander Wiring Diagram

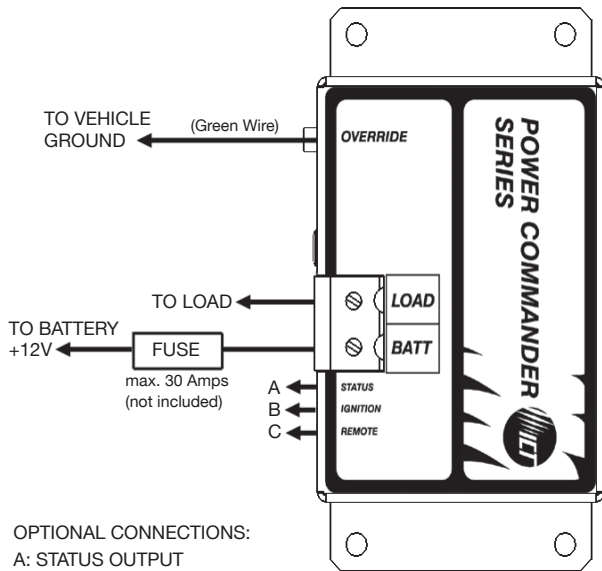

OPTIONAL CONNECTIONS:
 A: STATUS OUTPUT
 B: IGNITION SWITCH
 C: REMOTE OVERRIDE

Table 1: Power Commander DIP Switch Settings

1 2 3 4 5 6 7 8	Time Delay
■ ■ ■ ■ ■ ■ ■ ■	5 seconds
■ ■ ■ ■ ■ ■ ■ □	15 minutes
■ ■ ■ ■ ■ ■ □ ■	30 minutes
■ ■ ■ ■ ■ □ ■ ■	45 minutes
■ ■ ■ ■ □ ■ ■ ■	1 hour
■ ■ ■ □ ■ ■ ■ ■	1 hour, 30 minutes
■ ■ □ ■ ■ ■ ■ ■	2 hours
■ ■ □ ■ ■ ■ ■ ■	3 hours
■ ■ ■ ■ ■ ■ ■ ■	4 hours
■ ■ ■ ■ ■ ■ ■ ■	5 hours
■ ■ ■ ■ ■ ■ ■ ■	6 hours
■ ■ ■ ■ ■ ■ ■ ■	7 hours
■ ■ ■ ■ ■ ■ ■ ■	8 hours
■ ■ ■ ■ ■ ■ ■ ■	9 hours
■ ■ ■ ■ ■ ■ ■ ■	10 hours
■ ■ ■ ■ ■ ■ ■ ■	Infinity

Low Voltage Disconnect

1 2 3 4 5 6 7 8	Low Voltage Disconnect
■ ■ ■ ■ ■ ■ ■ ■	10.5 VDC
■ ■ ■ ■ ■ ■ ■ □	11.0 VDC
■ ■ ■ ■ ■ ■ □ ■	11.5 VDC
■ ■ ■ ■ ■ □ ■ ■	12.5 VDC

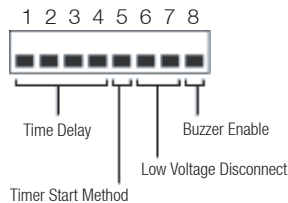

- Switches that are in the UP position are ON
- Switches that are in the DOWN position are OFF
- Not Relevant

Timer Start Methods: (refer to FEATURES section for description of operation)

Ignition Switch Activation: If using the Ignition Switch Activation method, connect the IGNITION terminal on the Power Commander to ignition switch terminal that goes to 0.0V when the ignition is turned OFF. Ensure that switch 5 of the DIP switch is ON (UP position) (see Table 1).

or

DC Voltage Detection: If using DC Voltage Detection method, ensure that switch 5 of the DIP switch is OFF (DOWN position) (see Table 1).

Note: The DC Voltage Detection method is selected by default.

Remote Override Button (Optional): For installations where the Power Commander override button is not in a convenient location, a remote override button can be connected to the unit. Connect a normally open (N.O.) momentary switch between the REMOTE terminal and vehicle ground.

Status Output – Shutdown Warning (Optional): The STATUS terminal is an open-collector output which is turned on for 2 minutes (except when using 5 second delay setting) before the timer shuts down.

LIMITED WARRANTY

ICT Ltd. warrants to the original consumer purchaser that this product shall be in good working order, free from defects in materials and workmanship, for a period of one (1) year from the date of purchase. Should failure occur during the above stated time period, then ICT will, at its option, repair or replace this product at no additional charge except as set forth below. All parts, whether for repair or replacement, will be furnished on an exchange basis. All exchange pieces become the property of ICT. This limited warranty shall not apply if the ICT product has been damaged by unreasonable use, accident, negligence, disaster, service, or modification by anyone other than the ICT factory.

Limited warranty service is obtained by delivering the product during the above stated one (1) year warranty period to an authorized ICT dealer or ICT factory and providing proof of purchase date. If this product is delivered by mail, you will insure the product or assume risk of loss or damage in transit, and prepay shipping charges to the factory.

Every reasonable effort has been made to ensure that ICT product manuals and promotional materials accurately describe ICT product specifications and capabilities at the time of publication. However, because of ongoing improvements and updating of ICT products, ICT cannot guarantee the accuracy of printed materials after the date of publication and disclaims liability for changes, errors or omissions.

If this ICT product is not in good working order, as outlined in the above warranty, your sole remedy shall be repair or replacement as provided above. In no event will ICT be liable for any damages resulting from the use of or the inability to use the ICT product, even if an ICT employee or an authorized ICT dealer has been advised of the possibility of such damages, or for any claim by any other party.

ICT reserves the right to make changes without further notice to any products or documentation for improvement of reliability, function, or design.

ICT Ltd. does not recommend use of its products in life support applications wherein a failure or malfunction of the product may directly or indirectly threaten life or cause injury. The user of ICT products, which are to be used in life support applications as described above, assumes all risks of such use and indemnifies ICT against all damages.

INNOVATIVE CIRCUIT TECHNOLOGY LTD.
 26921 GLOUCESTER WAY LANGLEY, BRITISH COLUMBIA, CANADA V4W 3Y3
 T 604.856.6303 F 604.856.6365 www.ict-power.com