

SPECIFICATIONS

► For stable operation of the secondary output, a minimum load is required at the primary output. (refer to specifications for minimum load requirement)

	Available Configurations					Input Voltage Range	Output Voltage	Output Current (Cont.)	Output Current (Peak)	Current Limiting	Line Regulation	Load Regulation	Output Ripple (Max)	Efficiency (Typical)	2nd Output Voltage	Min Load Required
	AO	AP	APB	APF	APFB											
ICT22012-12	●	●	●			105-130/ 185-250 VAC	13.8 VDC ±100mV	10.0 Amps	12.0 Amps	13.0 Amps	0.10%	0.10%	25 mV RMS	80%	---	---
ICT22012-18				●	●	105-130/ 185-250 VAC	13.8 VDC ±100mV	15.0 Amps	17.0 Amps	18.0 Amps	0.10%	0.10%	25 mV RMS	80%	---	---
ICT220125-13	●	●				105-130/ 185-250 VAC	13.8 VDC ±100mV	12.0 Amps	13.0 Amps	14.0 Amps	0.10%	0.10%	25 mV RMS	80%	---	---
ICT220125-18				●		105-130/ 185-250 VAC	13.8 VDC ±100mV	15.0 Amps	17.0 Amps	18.0 Amps	0.10%	0.10%	25 mV RMS	80%	---	---
ICT2201224-13	●	●				105-130/ 185-250 VAC	13.8 VDC ±100mV	10.0 Amps	13.0 Amps	14.0 Amps	0.10%	0.10%	25 mV RMS	80%	5.0 VDC	0.5 Amps
ICT2201224-18				●		105-130/ 185-250 VAC	13.8 VDC ±100mV	15.0 Amps	17.0 Amps	18.0 Amps	0.10%	0.10%	25 mV RMS	80%	27.6 VDC	0.5 Amps
ICT22024-6	●	●	●			105-130/ 185-250 VAC	27.6 VDC ±100mV	6.0 Amps	6.5 Amps	7.0 Amps	0.10%	0.10%	25 mV RMS	80%	---	---
ICT22024-8				●	●	105-130/ 185-250 VAC	27.6 VDC ±100mV	8.0 Amps	8.5 Amps	9.0 Amps	0.10%	0.10%	25 mV RMS	80%	---	---
ICT220245-6	●	●				105-130/ 185-250 VAC	27.6 VDC ±100mV	6.0 Amps	6.5 Amps	7.0 Amps	0.10%	0.10%	25 mV RMS	80%	---	---
ICT220245-8				●		105-130/ 185-250 VAC	27.6 VDC ±100mV	8.0 Amps	8.5 Amps	9.0 Amps	0.10%	0.10%	25 mV RMS	80%	---	---
ICT2202412-6	●	●				105-130/ 185-250 VAC	27.6 VDC ±100mV	6.0 Amps	6.5 Amps	7.0 Amps	0.10%	0.10%	25 mV RMS	80%	5.0 VDC	0.5 Amps
ICT2202412-8				●		105-130/ 185-250 VAC	27.6 VDC ±100mV	8.0 Amps	8.5 Amps	9.0 Amps	0.10%	0.10%	25 mV RMS	80%	13.8 VDC	0.5 Amps

AO - Open Frame APB - Panel Mount with Battery Back-Up APFB - Panel Mount with Fan and Battery Back-Up
AP - Panel Mount APF - Panel Mount with Fan

All models are CSA 22.2 No 107.1, UL 1012 Approved



ICT PANEL MOUNT SERIES INSTRUCTION MANUAL



OUTLINE DRAWING

DIMENSIONS IN
INCHES (MILLIMETRES)

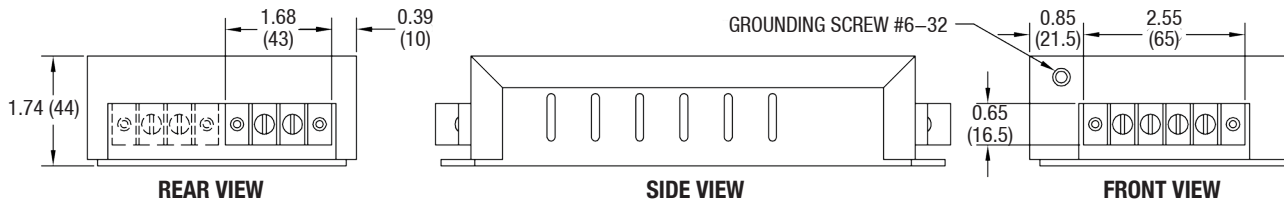
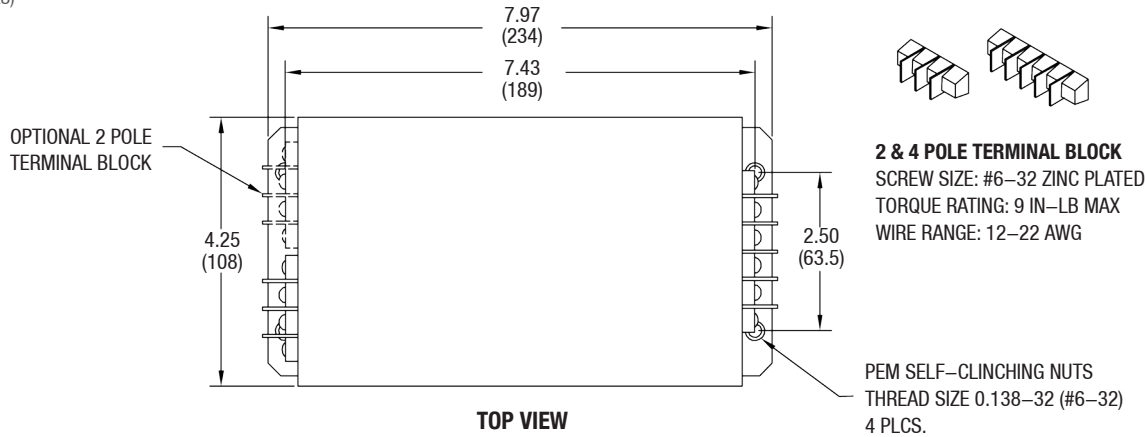

INNOVATIVE CIRCUIT TECHNOLOGY LTD.

855-110-002

ICT PANEL MOUNT SERIES

The ICT Panel Mount Series switching power supplies are intended for use as system components. The vented steel chassis construction ensures superior durability, while its threaded mounting holes facilitate easy and reliable installation. Terminal blocks are used for both input and output connections to provide versatility between all applications, perfect for use inside other equipment. Standard to all of the Panel Mount products is a 5V power good signal. Battery backup terminals, secondary low power outputs, forced air cooling, and open frame options are all available in this series.

These instructions should be read before using the product and it should be saved for future reference.

WARNING

- ▶ Internal servicing to power supply circuitry should be completed only by a qualified electronics technician.
- ▶ Any attempt to modify this power supply beyond its factory specifications may result in unit failure or personal injury.
- ▶ Only make connections to power supply with AC power disconnected.
- ▶ External 120/220 jumper must be correctly set to desired input voltage setting or power supply failure will occur.
- ▶ Maximum current drawn from 5v output monitoring signal should not exceed 5mA or power supply will become unstable.



NOTES

- ▶ The ICT Panel Mount Series products are component type power supplies designed for use in a wide variety of applications.
- ▶ The ICT AP series come standard with a selectable 120/220 Volt input, a 12 or 24 volt primary output, and a 5V output monitoring signal. Unique to the Panel Mount series is the option for a secondary low current output or battery backup/float charger, which may be operated continuously with the primary output.
- ▶ Panel Mount series power supplies with model numbers ending in 'B' have an additional terminal for lead acid battery backup. If AC power fails while a battery is connected to the battery terminal the primary output is maintained by the battery. While AC power is present and a battery is connected, the battery is float charged from the main output. This feature offers short circuit and fused reverse connection protection.
- ▶ An Aluminum vented lid comes standard on the Panel Mount Series however, it may also be ordered without a lid or with forced air cooling.
- ▶ Secondary output current is limited by an internal fuse. Remove power to the unit before replacing fuse.

CONNECTIONS

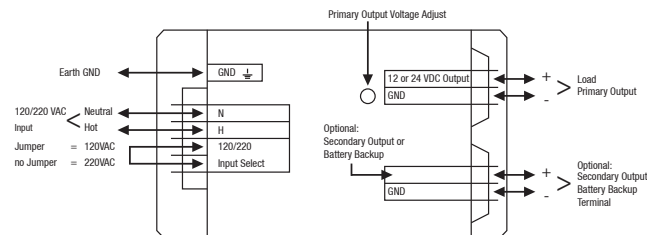

LIMITED WARRANTY

ICT Ltd. warrants to the original consumer purchaser that this product shall be in good working order, free from defects in materials and workmanship, for a period of one (1) year from the date of purchase. Should failure occur during the above stated time period, then ICT will, at its option, repair or replace this product at no additional charge except as set forth below. All parts, whether for repair or replacement, will be furnished on an exchange basis. All exchange pieces become the property of ICT. This limited warranty shall not apply if the ICT product has been damaged by unreasonable use, accident, negligence, disaster, service, or modification by anyone other than the ICT factory.

Limited warranty service is obtained by delivering the product during the above stated one (1) year warranty period to an authorized ICT dealer or ICT factory and providing proof of purchase date. If this product is delivered by mail, you will insure the product or assume risk of loss or damage in transit, and prepay shipping charges to the factory.

Every reasonable effort has been made to ensure that ICT product manuals and promotional materials accurately describe ICT product specifications and capabilities at the time of publication. However, because of ongoing improvements and updating of ICT products, ICT cannot guarantee the accuracy of printed materials after the date of publication and disclaims liability for changes, errors or omissions.

If this ICT product is not in good working order, as outlined in the above warranty, your sole remedy shall be repair or replacement as provided above. In no event will ICT be liable for any damages resulting from the use of or the inability to use the ICT product, even if an ICT employee or an authorized ICT dealer has been advised of the possibility of such damages, or for any claim by any other party.

ICT reserves the right to make changes without further notice to any products or documentation for improvement of reliability, function, or design.

ICT Ltd. does not recommend use of its products in life support applications wherein a failure or malfunction of the product may directly or indirectly threaten life or cause injury. The user of ICT products, which are to be used in life support applications as described above, assumes all risks of such use and indemnifies ICT against all damages.

This device complies with Part 15 of the FCC Rules. Operation is subject to the following 2 conditions:

1. This device may not cause harmful interference, and
2. This device must accept any interference received, including any interference that may cause undesired operation.

INNOVATIVE CIRCUIT TECHNOLOGY LTD.

26921 GLOUCESTER WAY LANGLEY, BRITISH COLUMBIA, CANADA V4W 3Y3

T 604.856.6303 F 604.856.6365 www.ict-power.com